



Enriching Lives

SLUICE VALVE

AS PER IS : 14846



KIRLOSKAR BROTHERS LIMITED
A Kirloskar Group Company

SLUICE VALVE

Widely accepted by Municipal Corporations, Irrigation Authorities, Water Supply Authorities, National Thermal Power Corporation, Nuclear Power Corporation and Industrial users.

Designed as per latest editions of IS specifications.

Certified by Bureau of Indian Standards for Non rising spindle Sluice Valves (ISI Marking)

Applications :

- Suitable for Isolation duty (Full Open / Full Close)
- Clear water having turbidity up to 5000 ppm and temperature up to 45°C
- Other fluids with maximum pressure / temperature conditions within the scope of IS: 14846
- Valves can be designed specialty with suitable material of construction for temperature up to 180 centigrade with limited pressure condition

Salient Constructional Features :

- Rigid and sturdy design with minimum loss of head across the valve
- Perfect interchangeability of components
- Perfect machining and Press fitting of body and wedge rings
- Excellent finish on spindle threads resulting in low friction and smooth operation of valves
- Assured leak tightness for long service life
- Perfect machining and Press fitting of body and wedge rings

Accessories :

- Cap Top
- Position Indicator
- Repacking (Back Seat) arrangement
- Spur / Bevel / Worm gear arrangement
- Thrust bearing arrangement
(200 NB and above sizes)
- Channel and Shoe arrangement (Renewable)
(300 NB and above sizes)
- Locking arrangement / Chain Padlock arrangement
- Extension shafting and head stock
- Electric Actuator
- Drain plug
- Chain and Chian Wheel arrangement
- Pneumatic Cylinder actuator
- Hydraulic Cylinder actuator
- Limit switch arrangement
- Companion Flange
- Glandless Design
- By pass Arrangement (300 NB and above sizes)

Hydrostatic Test Pressures :

Scope	Size Range	Manufacturing Standard and Pressure Rating (MPa)	Hydrostatic test Pressures Kg /Cm2 (MPa)	
			Body	Seat
Standard	40 mm to 1800 mm	IS : 14846 PN 1.0	15.3 (1.5)	10.2 (1.0)
Supply	40 mm to 1800 mm	IS : 14846 PN 1.6	24.47 (2.4)	16.32 (1.6)
Optional	For Higher Pressure ratings PN : 2.0 / 2.5 / 3.0 can be supplied on case to case basis.			

Material of Construction :

Scope	Standard supply	Optional
Body / Wedge / Dome	Cast Iron	SG. Iron as per IS : 1865, 2% NiCl, ASTM A 439 Type D2, Cast Steel as per IS : 1030 / ASTM A 216 Gr WCB
Body / Wedge / Rings	Leaded Tin Bronze as per IS : 318 Gr. LTB - 2	SS ASTM A276 Type 304 / 316 / 410 / 304L / 316L / SS IS 6603
Spindle	St. Steel as per IS : 6603 Gr. 12Cr12	High Tensile Brass; St. Steel as per IS : 1570; IS : 6603; ASTM A 276, BS : 970
Stem Nut	Leaded Tin Bronze as per IS : 318 Gr. LTB - 2	High Tensile Brass

Note: 1. For special material of construction, please contact Design Office.

2. Valves with Corrocoat Coating for Potable, Sewage, Corrosive fluids application can also be supplied on request.

End Connection :

Scope	Flange Drilling Standard
Standard Supply	IS : 1538 - Table 4 and 6
Optional	BS : 10 - Table D / E / F
	BS EN 1092.2 PN10, PN16
	IS : 1538 Table 5
	ANSI B 16.1 / 16.5
	DIN 2532 (ND 10)
	IS : 6392

NON RISING SPINDLE SLUICE VALVE

General Outline Drawings :

40 mm to 600 mm NRSSV

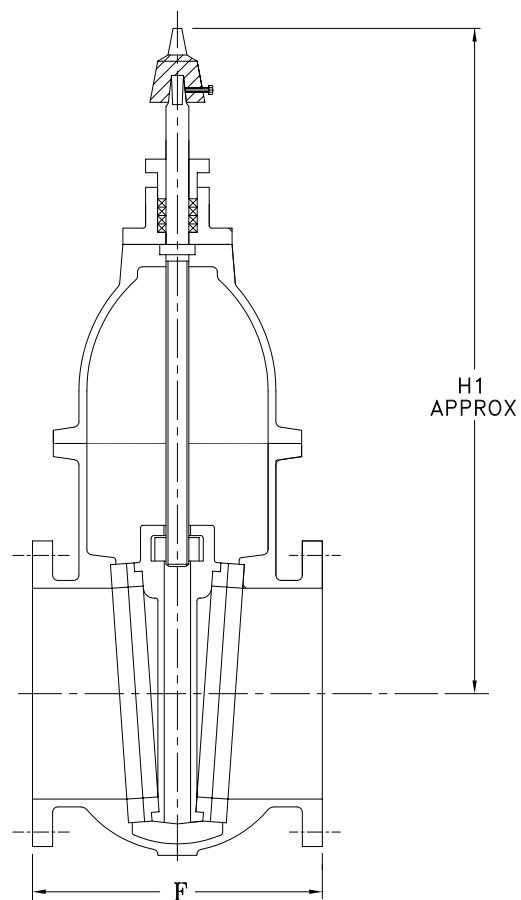
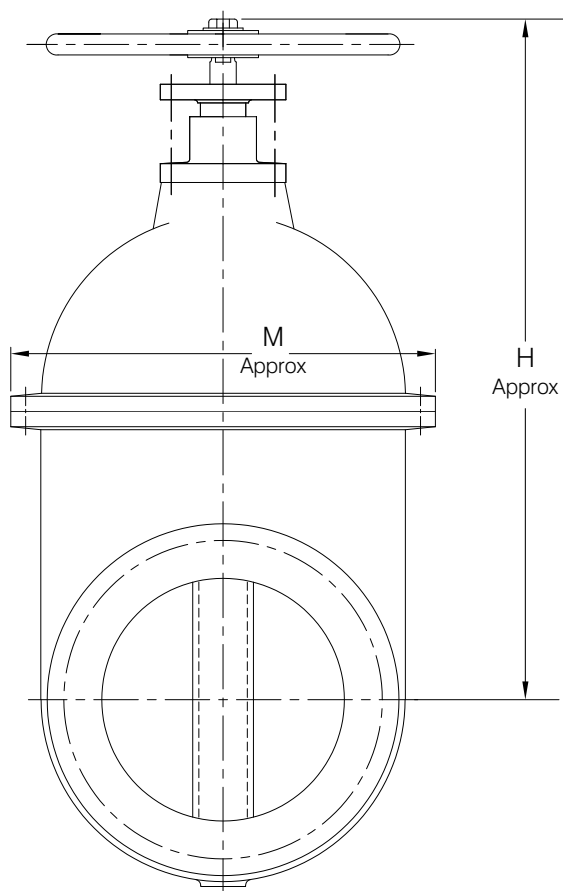

General Outline Dimensions :

40 mm to 600 mm NRSSV

Rating	Valve Size	F	M	H	H1
PN 1.0 and PN 1.6	40	165	124	290	350
	50	178	143	350	410
	65	190	214	365	425
	80	203	218	405	460
	100	229	144	460	550
	125	254	280	515	575
	150	267	312	555	630
	200	292	444	720	775
	250	330	482	810	875
	300	356	574	910	1010
	350	381	640	910	1050
	400	406	680	986	1105
	450	432	770	1193	1267
	500	457	860	1217	1337
	600	508	940	1400	1479

Note : 1. All dimensions are in 'mm' otherwise stated.

General Outline Drawings :

700 mm to 1800 mm NRSSV

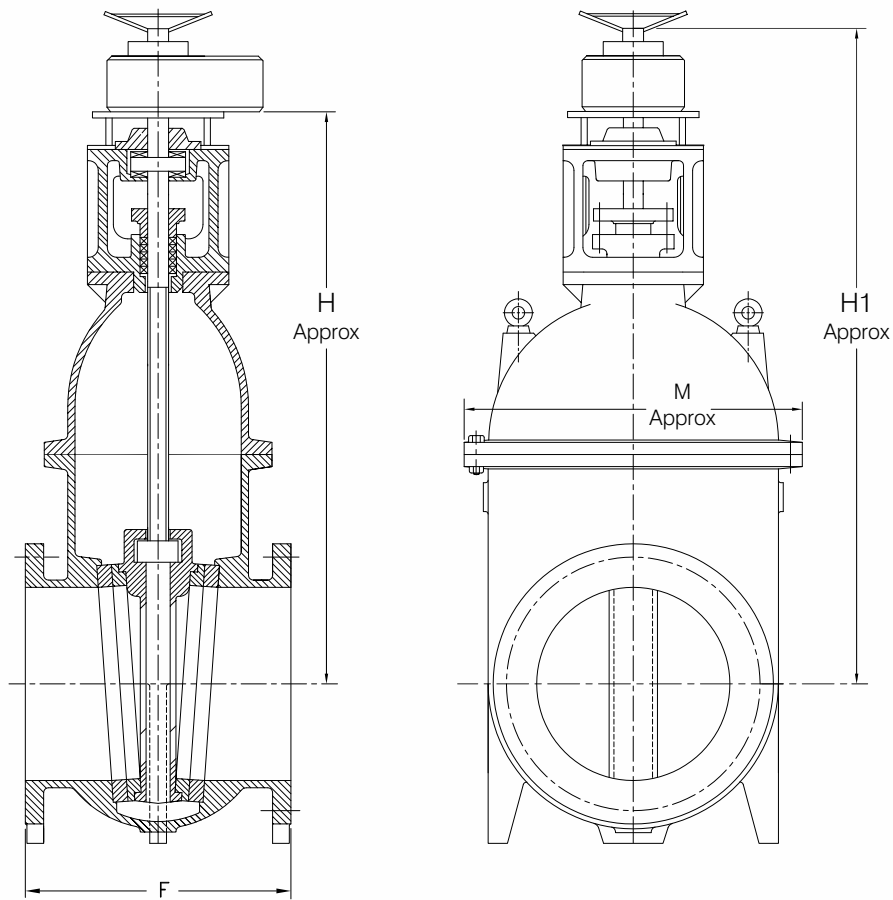

General Outline Dimensions :

700 mm to 1800 mm NRSSV

Rating	Valve Size	F	M	M For PN 1.6	H	H1 (With Gear Box)
PN 1.0 and PN 1.6	700	610	1120	1150	1850	2170
	750	610	1170	1240	2070	2400
	800	660	1220	1264	2100	2450
	900	711	1330	1330	2280	2650
	1000	811	1490	1490	2440	2800
	1100	811	1610	1660	2690	3050
	1200	810	1670	1670	2690	3050
PN 0.6 / 1.0 / 1.6	1300	1016	1837	1937	2950	3450
	1500	1118	2152	2152	3530	4000
	1800	1118	2537	2537	4230	4900

Note : 1. All dimensions are in 'mm' otherwise stated.

RIISING SPINDLE GATE VALVE

General Outline Drawings :

40 mm to 300 mm RSGV

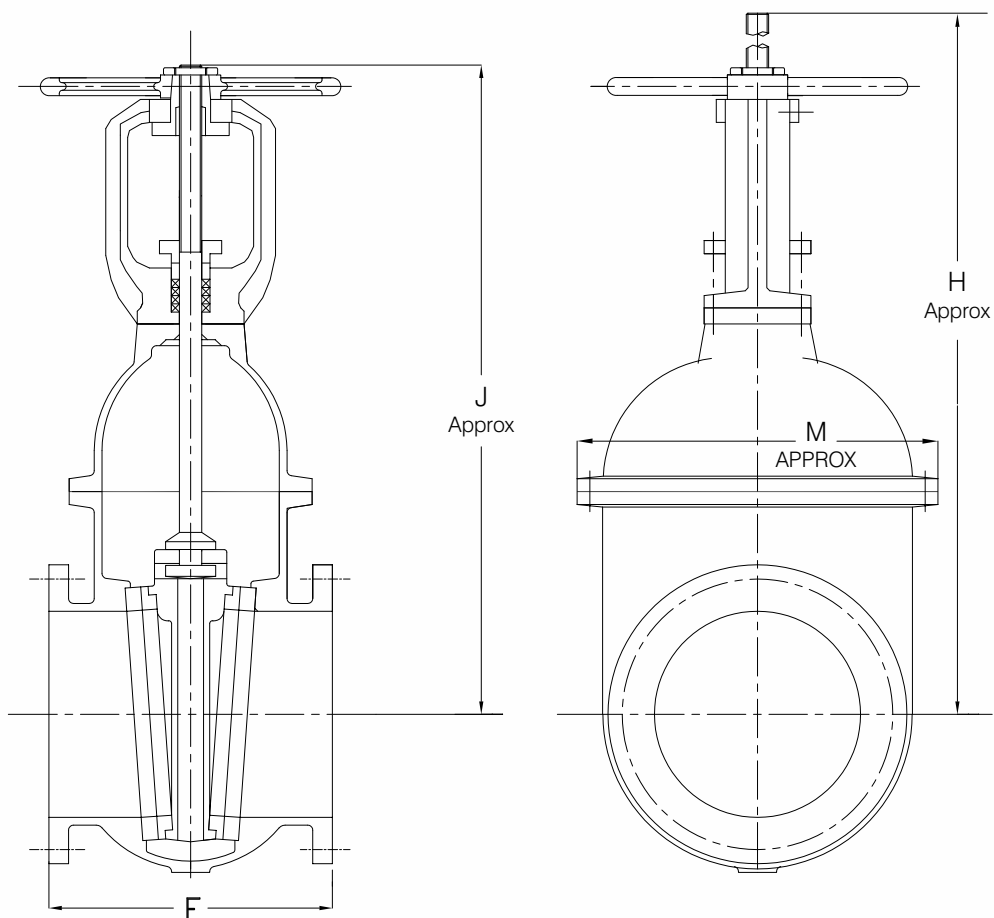

General Outline Dimensions :

40 mm to 300 mm RSGV

Rating	Valve Size	F	M	J- Shut	H- Open
PN 1.0 and PN 1.6	40	165	124	125	430
	50	178	143	135	510
	65	190	214	165	537
	80	203	218	195	553
	100	229	244	230	675
	125	254	280	265	785
	150	267	312	300	904
	200	292	444	325	1177
	250	330	482	355	1366
	300	356	574	390	1566

Note : 1. All dimensions are in 'mm' otherwise stated.

General Outline Drawings :

350 mm to 1500 mm RSGV

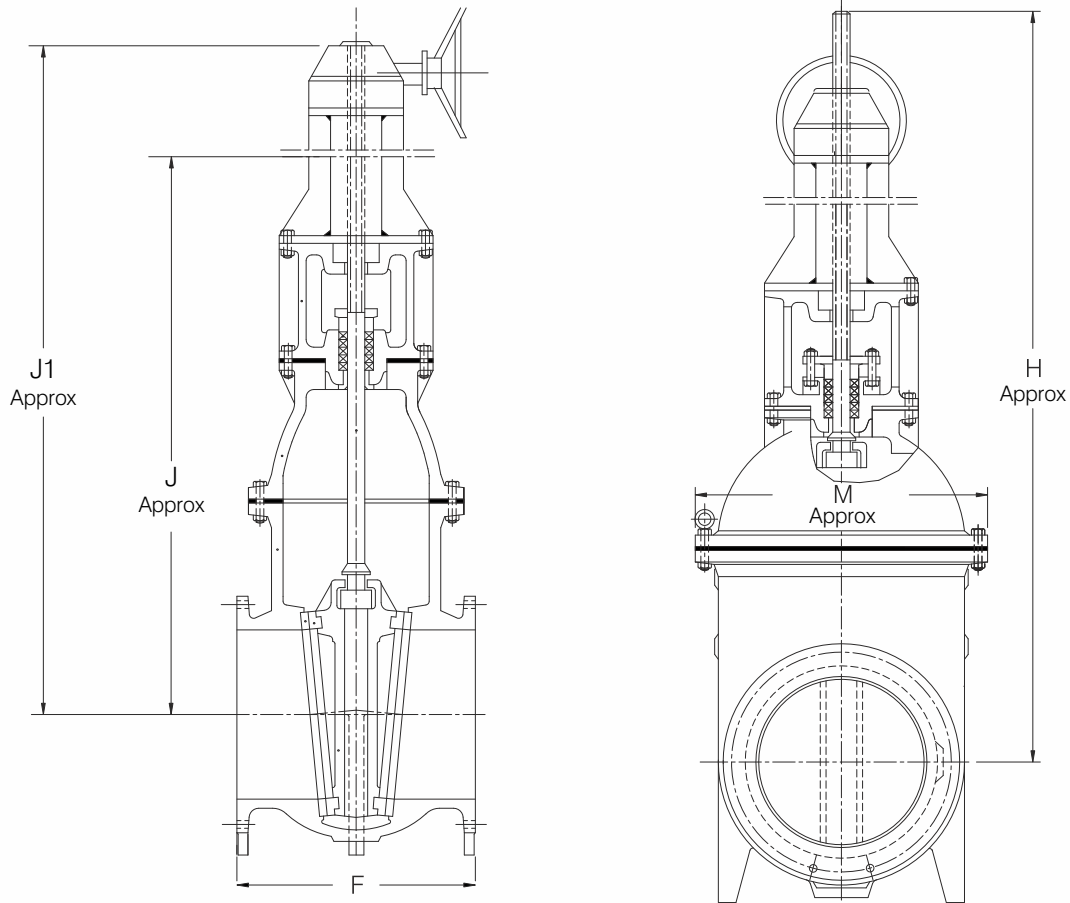

General Outline Dimensions :

350 mm to 1500 mm RSGV

Rating	Valve Size	F	M	J- shut	J1- Shut (With Gear Box)	H - Open
PN 1.0 and PN 1.6	350	381	640	1320	1550	1750
	400	406	680	1450	1700	1860
	450	432	770	1600	1850	2120
	500	457	860	1715	1910	2285
	600	508	940	1955	2200	2625
	700	610	1120	2647	2750	3371
	750	610	1170	2830	3000	3670
	800	660	1220	2640	3000	3475
	900	711	1330	3035	3300	3970
	1000	811	1444	3370	3800	4570
	1100	811	1610	3750	4000	4590
1200	810	1670	3900	3900	5100	
PN 0.6 / 1.0 / 1.6	1500	1118	2152	5400	5400	6540

Note : 1. All dimensions are in 'mm' otherwise stated.

ABOUT KBL

Kirloskar Brothers Limited (KBL) is a world class pump manufacturing company with expertise in engineering and manufacture of systems for fluid management. Established in 1888 and incorporated in 1920, KBL is the flagship company of the \$ 2.1 billion Kirloskar Group. KBL, a market leader, provides complete fluid management solutions for large infrastructure projects in the areas of water supply, power plants, irrigation, oil & gas and marine & defence. We engineer and manufacture industrial, agriculture and domestic pumps, valves and hydro turbines.

In 2003, KBL acquired SPP Pumps, United Kingdom and established SPP INC, Atlanta, USA, as a wholly owned subsidiary of SPP, UK to expand its international presence. In 2007, Kirloskar Brothers International B.V., The Netherlands and Kirloskar Brothers (Thailand) Ltd., a wholly owned subsidiary in Thailand, were incorporated. In 2008, KBL incorporated Kirloskar Brothers Europe B.V. (Kirloskar Pompen B.V. since June 2014), a joint venture between Kirloskar International B.V. and Industrial Pump Group, The Netherlands. In 2010, KBL further consolidated its global position by acquiring Braybar Pumps, South Africa. SPP MENA was established in Egypt in 2012. In 2014, KBL acquired SyncroFlo Inc., the largest independent fabricator of commercial and municipal domestic water booster pumps.

To further strengthen its global position, in 2015, Kirloskar Pompen B.V. acquired Rodelta Pumps International, The Netherlands.

KBL has joint venture cooperation with Ebara, Japan since 1988 for the manufacture of API 610 standard pumps. Kirloskar Corrocoat Private Limited is a joint venture cooperation with Corrocoat, UK since 2006. KBL acquired The Kolhapur Steel Limited in 2007 and Hematic Motors in 2010.

KBL has eight manufacturing facilities in India at Kirloskarvadi, Dewas, Kondhapuri, Shirwal, Sanand, Kaniyur, Kolhapur and Karad. In addition, KBL has global manufacturing and packaging facilities in Egypt, South Africa, Thailand, The Netherlands, United Arab Emirates, United Kingdom and United States of America. KBL has 12,700 channel partners in India and 80 overseas and is supported by best-in-class network of Authorised Centres and Authorised Refurbishment Centres across the country.

All the manufacturing facilities at KBL are certified for ISO 9001, ISO 14001, ISO 50001, BS OHSAS 18001 and SA8000. In addition, the Kirloskarvadi plant is also certified for N & NPT Stamp. KBL's corporate office in Pune is certified for ISO 9001 & Sa8000.

The factories deploy Total Quality Management tools using European Foundation for Quality Management (EFQM) model. The Kirloskarvadi plant of KBL is a state-of-the-art integrated manufacturing facility having Asia's largest hydraulic research centre with testing facility upto 5000 kW and 50,000 m³/hr.

KBL is the ninth pump manufacturing company in the world to be accredited with the N and NPT certification by American Society of Mechanical Engineers (ASME).

Pumps | Valves | Hydro Turbines | Turnkey Projects

Water Resource Management | Irrigation | Power | Industry | Oil & Gas | Marine & Defence | Building & Construction | Distribution (Small Pumps) | Valves | Customer Service & Spares

KIRLOSKAR BROTHERS LIMITED

A Kirloskar Group Company

Registered Office: Udyog Bhavan, Tilak Road, Pune 411002. Tel: +91(20)24440770, Global Headquarters: "Yamuna", Survey No. 98/(3.7), Baner, Pune 411045. Tel: +91(20)27214444, Email: marketing@kbl.co.in, Website: www.kirloskarpumps.com, CIN No.: L29113PN1920PLC000670

OUR COMPANIES



Kirloskar Brothers Limited reserve the right to make alteration from time to time and such our products / equipments may differ from that detail in this publication. For latest information you may get in touch with our Regional Sales Offices.